

ORIGA RODLESS CYLINDERS @ WORK: CARTON TRANSFER

Problem

A manufacturer required a method of increasing the expected life of a carton transfer system which was required to operate 24 hours a day, 7 days a week and loading at speeds in excess of 1 m/sec.

Solution

A P210, 25mm diameter, 500mm stroke Origa Rodless cylinder was installed, having Origa SA25 shock absorbers fitted to each end of the stroke together with VOE's actuated by RS proximity switches has introduced controlled travel and efficient deceleration.

Results

- Simple design
- Self-guiding mechanism
- Life expectancy greatly increased
- Reduced noise and vibration
- Low maintenance
- Increased productivity

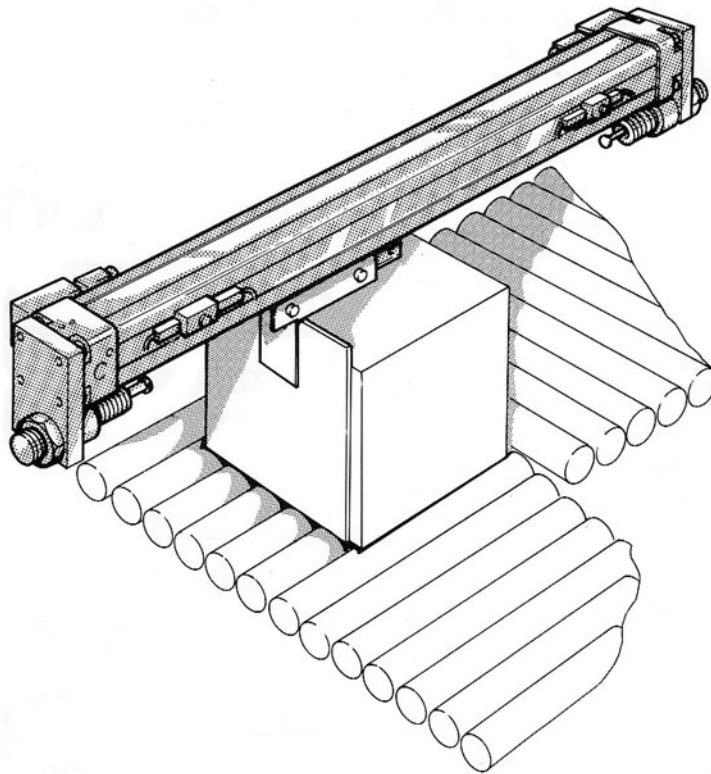

Origa Rodless
Cylinders
@Work:
Carton
Transfer

Applications